

RANCHER Quick Guide

This Quick Guide shows the basic operation of the WATERAX RANCHER 65/125 gallon skid unit.

- The WATERAX RANCHER pairs a WATERAX single-stage pump end with a Honda GXH50 gasoline engine (MINI-STRIKER), and a 65-gal or 125-gal tank. For instructions regarding the engine, as well as for oil and fuel recommendations, please refer to the engine manufacturer's manual.
- For detailed instructions on using and troubleshooting your pump, as well as full service and maintenance instructions, refer to our website to download the *RANCHER Owner's Manual*.
- For full specifications and performance curves, see the *RANCHER Data Sheet*.



Warnings and Safety Precautions

This warning label appears on all WATERAX pumps to identify safety hazards as follows:



READ YOUR ENGINE MANUAL!

Before proceeding further, locate and read the engine manufacturer's manual. It contains very important safety information that **MUST** be read, understood and followed to safeguard you and your equipment from harm, as well as for the proper use and care of your engine. Use only fuel and oil type recommended in the engine manufacturer's manual. Always check oil level in crankcase before use.



WEAR EAR AND EYE PROTECTION.

Always wear eye and ear protection when operating the pump unit. Sound level of the unit: 91 dB(A).



GENERAL WARNINGS:

- Do not operate if mentally or physically fatigued.
- Inspect hoses and piping to avoid burst injuries.
- No modifications and/or alterations may be made to the pump. Any such modifications void the pump warranty and can endanger pump operators.
- Do not operate the pump above the maximum rated pressure. Use only pipe, hose, and fittings rated at or above the maximum pressure rating of the pump or system design.
- Slowly close valves. Use slow close valves wherever possible to safeguard operators and prevent damage from water hammer.
- Dry weight of the unit: 159 lbs (with 65-gal tank) or 202 lbs (with 125-gal tank).



READ THE PUMP OWNER'S MANUAL!

The improper use of this pump could result in serious injuries as well as damage to the unit. Read the *RANCHER Owner's Manual* before using your RANCHER unit and follow the safety instructions in this Quick Guide.



NEVER RUN THE ENGINE IN A CLOSED OR CONFINED AREA. Exhaust gas contains carbon monoxide which is poisonous to humans. Avoid inhalation of exhaust gas.



REFUEL ENGINE WITH CARE. Gasoline is extremely flammable, and gasoline vapor can explode. Refuel in a well-ventilated area, with the engine stopped.



NEVER TOUCH ANY EXHAUST SYSTEM PARTS WHILE ENGINE IS RUNNING. Always allow enough time, after stopping the unit, for proper cooling of these parts and surrounding areas.

EQUIPMENT DAMAGE PREVENTION:

- Flush the pump with fresh water if the pump has been used to pump salty, brackish, high mineral content water, water containing debris, or foam injected water. Check that debris is cleared before using the pump again.
- Always draft water using a suction hose strainer.

RANCHER Quick Guide

Parts Identification

- A. 50' booster hose (3/4") and nozzle
- B. MINI-STRIKER pump
- C. Tank fill opening
- D. Overboard discharge port
- E. Class A foam eductor system* (option)
- F. Overboard suction port
- G. Overboard discharge valve
- H. Reel discharge valve
- I. Foam discharge valve*
- J. Recirculation valve
- K. Suction valve

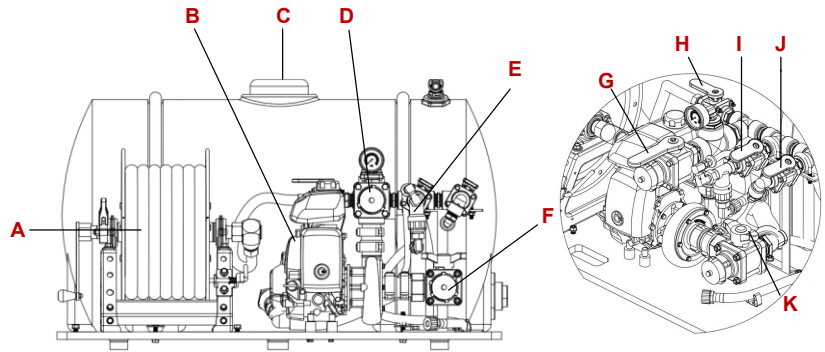

* Denotes optional components.

To operate the RANCHER unit:

1. Fill water tank with clean water.

Fill the tank directly through the water tank opening or by drafting from an auxiliary water source using the pump (requires an optional 1-1/2" suction hose and a footvalve).

To draft water and fill the tank from an auxiliary water source:

- a. Position the 3-way suction valve to the overboard suction position.
- b. Close all discharge valves and open the recirculation valve.
- c. Prime the pump.
- d. Start the engine.
- e. The pump will draft water from the auxiliary source and fill the tank through the recirculation line.
- f. Turn off the engine when the tank has been filled.

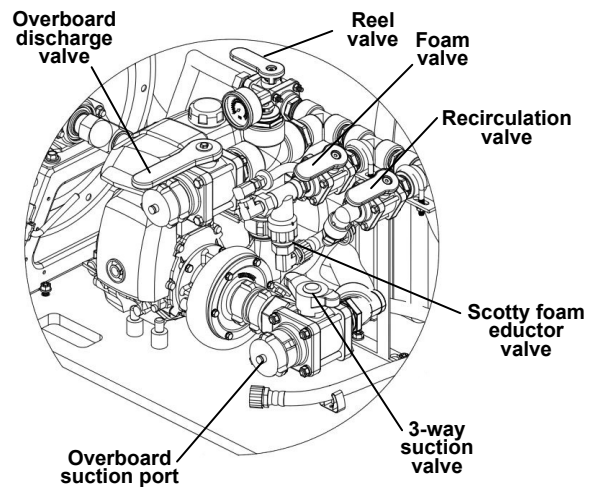

2. Fill the fuel tank with recommended fuel grade and securely replace cap. Check oil level (see engine manual).

3. Select the suction mode.

Position the 3-way valve to the desired suction port. If using the overboard suction, connect the suction hose and footvalve strainer. Use a universal hose coupling wrench to tighten coupling firmly.

If the RANCHER unit is equipped with a foam eductor system, **close the foam eductor valve** prior to engine start by turning the adjustment knob counter clockwise.

4. Prime the pump.

Use a WATERAX hand primer or jerk the hose to ensure that water has entered the pump before starting the engine.

If the pump is primed from the tank through gravity, open the overboard discharge cap and discharge valve and allow some water to flow out in order to relieve the system of any air lock.

! DO NOT allow the strainer to rest on bottom of lake or riverbed. Check strainer frequently to make sure that it is not clogged with moss, leaves, etc.

! DO NOT lift strainer from water while the pump is operating. Use a rope or other means to keep strainer at proper height, approximately 1 foot (30 cm) below water surface. If strainer is too close to the water surface, it will draw air and pump may lose prime.

5. **Connect discharge hose, nozzles, etc.,** to pump, and tighten firmly with coupling wrench.
6. **Start the engine.**
 - a. Open fuel valve.
 - b. Close/engage choke, if engine is cold.
 - c. Increase throttle past the idle position.
 - d. Position the ignition switch to the ON position.
 - e. Close all discharge and recirculation valves.
 - f. Give starter rope a quick and steady pull until engine starts.
 - g. Open/disengage choke.
 - h. Slightly open the recirculation valve. Water should be recirculating back into the tank. If there is no water recirculating, the pump has not been fully primed. Re-prime the pump.
 - i. Allow the engine to warm up for at least 2 minutes before using full throttle.

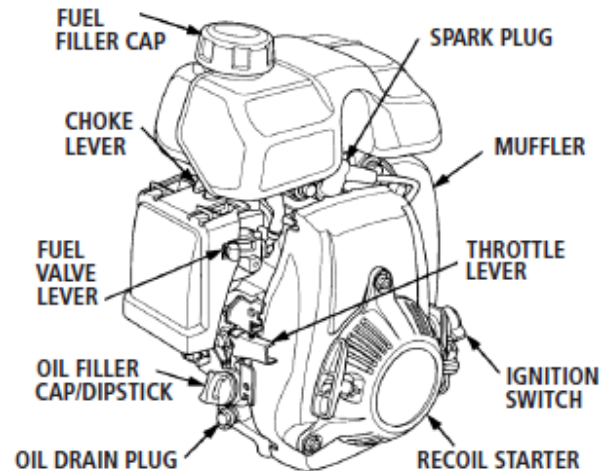

7. Discharge water.

Once the pump is primed, and with the engine running, you can begin to discharge water.

- a. Slowly open the discharge valve.
 - To use the hose reel, slowly open the Reel valve and close the Overboard discharge and Recirculation valves.
 - To use the overboard discharge, slowly open the Overboard discharge valve and close the Reel and Recirculation valves.
- b. Adjust the pump performance by throttling the engine up or down, or opening or closing discharge valve at various positions, or any combination of the two.

! DO NOT leave the pump running with all the discharge valves closed for more than one minute, or else the pump may overheat and become damaged. To avoid this, open the recirculation valve to allow fresh water to continue to enter the pump.

! DO NOT open the recirculation valve if the foam eductor is in function to avoid pumping foam in the tank. If this occurs, it is recommended to flush out the tank with fresh water.

8. Apply foam (if applicable, and if equipped with the optional Scotty Around the Pump foam eductor).

- a. Ensure that the recirculation valve is **closed** when using foam.
- b. Open the Scotty foam eductor valve to the desired eduction ratio.
- c. Select the water discharge method. You can either discharge water through the hose reel or through the discharge valve.
- d. When you are done using the foam, be sure to flush the system thoroughly for at least 2 minutes. To flush the Scotty foam eductor, close the eductor valve and circulate fresh water through the eductor.

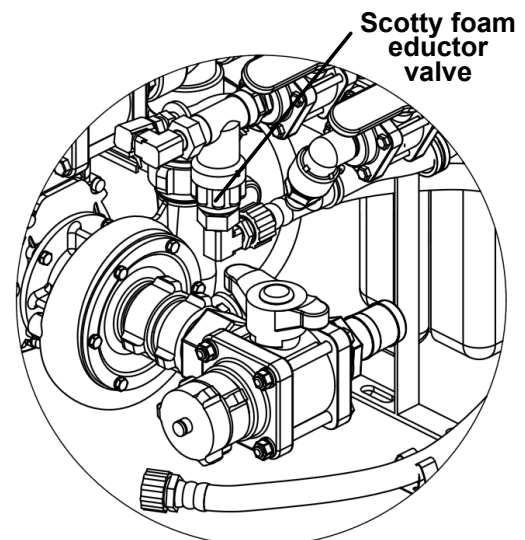

Optional Foam System

RANCHER Quick Guide

To shut down and store the RANCHER unit:

1. **Shut down the pump.**
 - a. Gradually reduce the engine speed.
 - b. If equipped, close the foam eductor valve and pump out the water/foam mixture until the water is clear.
 - c. Open the recirculation valve and close all other discharge valves. Allow the water to circulate until the engine cools down. Whenever the unit has been run at full throttle for most of the operation, run the engine at idle for approximately 2 minutes before shutting down the unit.
 - d. If the unit is to be stored, move the fuel valve lever to the OFF position and wait for the engine to stop. Otherwise, set the ignition switch to the OFF position to shut down the engine.
 - e. Close off the hydrant/supply to the pump.
 - f. Open all valves to relieve any pressure left in the system.

2. **Check and store the pump.**
 - a. If the pump was last run with foam or water that is salty, brackish or high in mineral content, flush the pump with fresh water for a minimum of 2 minutes or until the water is clear.
 - b. Run the pump to drain out as much water as possible from the tank without letting the pump run completely dry or lose prime. Some water will remain in the tank.
 - c. Close the discharge and reel valves. Close the foam valve (if equipped).
 - d. Make sure the recirculation valve is open.
 - e. For cold weather storage, add some antifreeze to the tank, and allow the pump to run for about 30 seconds to allow the water and antifreeze mix to circulate through the pump and the hose reel. Your pump will now be protected from damage due to freezing.
 - f. Empty any remaining fluids in the water tank.
 - g. Empty any fluids in the hose on the reel.
 - h. After the unit has cooled down, check all fluid levels and add as needed.
 - i. Completely drain the pump of all water.
 - j. Break down and store all equipment as outlined by the apparatus or department procedures.
 - k. Visually inspect the pump end. Clean any dirt or debris from the pump unit. If necessary, a mild soap and water solution can be used. Note and report any performance irregularities or any abnormal mechanical sounds.
 - l. Close all valves and plug all openings.
 - m. Follow any other product, component, apparatus, and departmental procedures and/or guidelines before placing the unit in storage. Make sure all necessary tools, spares, and accessories are with the pump.

To operate the RANCHER unit in cold weather:

- The pump can be run in below freezing temperatures if certain precautions are taken to avoid the formation of ice in the pump.
- After priming the pump, the unit should be run at low speed for a short period of time to allow all components to warm up before continuing with the remaining operating procedures.
- Unless wrapped in a heater, drain the pump of all water if it is stopped for any length of time. The engine/drive unit should be turned over a few revolutions to make sure all water has been removed from the pump. Drain the pump priming line if a primer has been used.
- After use, drain the pump, manifolds, and lines of all water. You can also pour some antifreeze into the pump and circulate it through the pump and plumbing system.

Warranty, Service and Support

Product and service documentation such as tech notes, data sheets, manuals and information on the limited warranty provided on products manufactured by WATERAX can be found on our Web site at: www.waterax.com

WATERAX Inc.

6635 Henri-Bourassa W.
Montreal, QC H4R 1E1
Tel.: (855) 616-1818
(514) 637-1818
Fax: (514) 637-3985
E-mail: info@waterax.com

Copyright © 2015 WATERAX Inc. Publication Number: 701234 Rev.2 All rights reserved. Printed in Canada.