

### EPRIMERKIT – Electric Primer Kit

#### **Overview:**

Designed for vehicle mounted pump units, the **EPRIMERKIT** provides a complete set of components to facilitate integration on vehicle platforms. Having the ability to prime a pump within seconds, this powerful piston pump is coupled to a short duration rated 12 volt D.C. motor. Made of corrosion-resistant materials, it is designed to exceed forestry and municipal drafting and skid mount requirements. This document outlines the proper installation method, operations, and replacement parts for the **EPRIMERKIT**.

#### **Kit Components:**

The **EPRIMERKIT** is provided with a wiring harness and a momentary ON/OFF switch. A mounting hole for this switch is provided in the **WATERAX** Control Panel (**WCP**) or Panel Mount Standard Control Panel (**PMSCP**). Mechanical support and anti-vibration mounts provided with the priming unit dampen the Electric Primer's (**B-7498**) vibrations. To further aid in the unit's integration, plumbing components have been provided.

**CAUTION:** To avoid high pressure water from damaging the Electric Primer, the priming valve must be closed after priming the centrifugal pump. Leaving the priming valve open in this situation can damage the priming system and/or cause injury.

For further information on the **B-7498** Electric Priming Pump, please refer to the User Instructions **B-7498** Electric Primer.



## USER INSTRUCTIONS

### **Installation:**

The kit comes with a separate momentary switch, valve assembly, mounting hardware, and 6 feet of clear PVC braided hose. The procedure for installing the unit is as follows:

**Step 1:** Use the Electric Primer Support plate to locate and drill the four 1/4 inch holes required for mounting the primer unit and use the Ball Valve Bracket to locate and drill the two 5/16 inch diameter holes required for mounting the ball valve assembly. In freezing conditions, make sure that the priming hose lines are properly drained.

**Step 2:** Bolt the electric priming pump using the two tapped holes in pump housing: two M8 x 1.25 screws and two M8 or 5/16" split lock washers.

**Step 3:** Adjust the elbow fittings to the required directions needed to align the tubing neatly in the installation. Should the elbows need to be changed, do not use a fitting with an I.D. less than 1/4 inch (6.5 mm).

**WARNING: Do not cover the drain hole (under primer body) as failure may occur.**

**Step 4:** Use the M6 x 1.0 nuts and M6 or 1/4" split lock washers to bolt the vibration mounts onto the support plate (**NOTE:** male end points upward).

**Step 5:** Bolt the assembly onto a solid base or frame using the M6 x 1.0 screws and M6 or 1/4" split lock washers.

**Step 6:** Install hose using provided Oetiker clamps (both not shown for clarity). **Note:** the hose may need to be cut to reduce the length to provide a nice neat layout.

**NOTE: If equipped with a WCP or PMSCP, please refer to the panels corresponding installation instructions for Step 7.**

**Step 7:** Install toggle switch in your WCP or PMSCP.

### **Wiring Installation:**

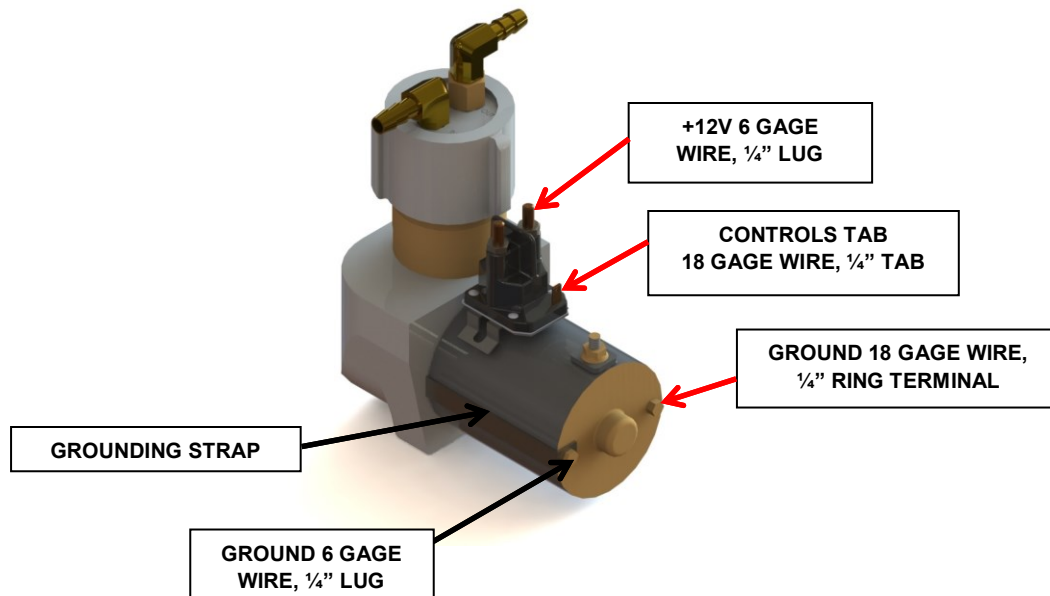

## USER INSTRUCTIONS

**Operation:** To prime the pump using the Electric Priming Pump, follow these steps:

1. Connect all pump intake and discharge equipment to the pump: suction hose, strainer, discharge hose, etc.
2. Make sure that the primer has power.
3. Open the priming valve.
4. With all discharge valves closed, intake valve open, and the suction hose placed in the water, activate the electric primer switch.
5. Watch the water rise in the suction hose until it reaches the pump or watch the discharge port of the electric primer until a straight stream of water starts to come out.

**CAUTION:** To prevent the primer motor from overheating, **DO NOT** hold the primer switch ON for more than 20 seconds per trial.

**IMPORTANT:** The B-7498 Electric Priming Pump is not designed to pump water. It is designed to draw the air out of the suction line. As soon as water starts to come out from the discharge port, release the primer switch to avoid damage to the electric primer.

6. Close the priming valve.
7. Turn on the fire pump and monitor pressure, at this point the pump should be primed and the pump should be ready to operate.
8. Once the discharge valve is open, pressure should build in the line.
9. If pressure does not build in the discharge line, open the priming ball valve again and operate the primer again.
10. Once the pressure builds in the discharge line, release the priming switch and close the priming ball valve.
11. Adjust the engine throttle and discharge valve until the desired pump performance is obtained.

### **Maintenance:**

*For servicing the Electric Priming Pump, please refer to the User Instructions B-7498 Electric Priming Pump.*

### USER INSTRUCTIONS

#### Parts Breakdown:

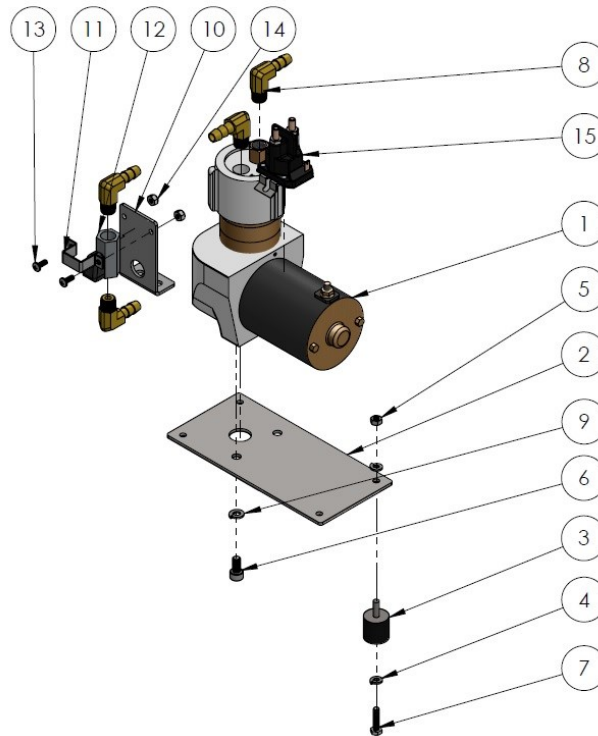

ID	ITEM NO	DESCRIPTION	QTY
1	600067	B-7498 ELECTRIC PRIMER	1
2	700264	A-7682 ELECTRIC PRIMER SUPPORT	1
3	800752	PART-310 ANTI-VIBRATION MOUNTS RNCH	4
4	800360	12-38 LOCKWASHER 1/4 SPLIT SS	8
5	800045	R-116 HEX NUT M6X 1.0	4
6	800336	FAST-746 SCREW M8X1.25X16 HEX SOCKET SS	2
7	800525	FAST-21 SCREW M6X1.0X25 HEX CAP ZINC	4
8	800703	PART-315 ELBOW BRB 3/8 TO MNPT 3/8, BR	4
9	800312	FAST-545 LOCKWASHER 5/16 SPLIT SS	2
10	700061	A-7690 BALL VALVE BRACKET EXHAUST PRIMER SKIDTANX	1
11	700062	A-7691 SQUARE CLAMP EXHAUST PRIMER SKIDTANX	1
12	800780	PART-348 VALVE BRASS MINI 3/8 NPT, WEDGE	1
13	700316	COR-1200-025 PAN HD SCREW #10-24 X1/2LG S/S	2
14	800421	FAST-732 NUT #10-24 HEX NYLON LOCK ZINC	2
15	800949	PART-446 RELAY 100A 12V WEATHER RESIST	1

ID	ITEM NO	DESCRIPTION	QTY
--	600245	TRPD-CBL-EP CABLE FOR ELECTRIC PRIMER	1
--	800790	QHOSSEVPC38 HOSE 3/8 ID, BRAIDED PVC	6
--	800317	FAST-537 WASHER 1/4 FLAT SS	2
--	800904	PART-381 SW TOGGLE, SPST, 15A, OFF-(ON)	1
--	800941	PART-422 LOCK RING 15/32" FOR TOGGLE SW	1
--	800942	PART-423 LOCK NUT 15/32" FOR TOGGLE SW	1
--	800947	PART-429 BINDING POST 3/8" RED	1
--	800921	PART-456 BATTERY BOOTS 8-2GA RED	1
--	800296	FAST-528 NUT 1/4-20 HEX NYLON LOCK SS	2
--	800389	PART-466 NUT 3/8-16 HEX LOW PROFILE BRASS	2
--	800344	PART-460 LOCKWASHER 3/8 SPLIT BRASS	2
--	800304	FAST-550 SCREW 5/16-18X3/4 HEX CAP SS	2
--	800749	PART-388 OETIKER DOUBLE EAR CLAMP .544" TO .669"	4
--	800380	PART-465 WASHER 3/8 X 7/8OD FLAT BRASS	2

**Warranty, Service and Support:**

Product and service documentation such as tech notes, data sheets, manuals and information on the limited warranty provided on products manufactured by *WATERAX* can be found on our Web site at: [www.waterax.com](http://www.waterax.com).

***WATERAX Inc.***

6635 Henri-Bourassa Blvd. W.  
Montreal, QC, H4R 1E1  
Tel.: (855) 616-1818  
(514) 637-1818  
Fax: (514) 637-3985  
E-mail: [info@waterax.com](mailto:info@waterax.com)

Copyright © 2015 *WATERAX Inc.* Publication Number: 700942, Rev.4 All rights reserved. Printed in Canada.